

Read Me First: Unpacking Express5800/320Fd System Cabinets

NEC Corporation of America
456-01741-000

Notice

The information contained in this document is subject to change without notice.

UNLESS EXPRESSLY SET FORTH IN A WRITTEN AGREEMENT SIGNED BY AN AUTHORIZED REPRESENTATIVE OF NEC, NEC MAKES NO WARRANTY OR REPRESENTATION OF ANY KIND WITH RESPECT TO THE INFORMATION CONTAINED HEREIN, INCLUDING WARRANTY OF MERCHANTABILITY AND FITNESS FOR A PURPOSE. NEC assumes no responsibility or obligation of any kind for any errors contained herein or in connection with the furnishing, performance, or use of this document.

Software described in NEC (a) is the property of NEC and/or its licensees, (b) is furnished only under license, and (c) may be copied or used only as expressly permitted under the terms of the license.

NEC documentation describes all supported features of the user interfaces and the application programming interfaces (API) developed by NEC and/or its licensees. Any undocumented features of these interfaces are intended solely for use by NEC personnel and are subject to change without warning.

This document is protected by copyright. All rights are reserved. No part of this document may be copied, reproduced, or translated, either mechanically or electronically, without the prior written consent of NEC Corporation of America.

The NEC Corporation of America logo, Express5800/320Fd, and the Express5800/320Fd logo, are trademarks of NEC Corporation of America. ActiveService Network is a trademark of Stratus Technologies Bermuda, Ltd. All other trademarks and trade names are the property of their respective owners.

Manual Name: *Read Me First: Unpacking Express5800/320Fd System Cabinets*

Part Number: 465-01741-000

Revision Number: 0

Publication Date: July 2008

NEC Corporation of America
10850 Gold Center Drive, Suite 200
Rancho Cordova, CA 95670

Contents

| | |
|---|----|
| Introduction | 1 |
| Packaged Cabinet | 1 |
| Before Unpacking the Cabinet | 3 |
| Moving the Cabinet to the Installation Site | 6 |
| Unpacking and Checking the Cabinet | 7 |
| Tools Needed to Unpack the Cabinet | 8 |
| Removing the Packing Materials | 8 |
| Removing the Cabinet from the Pallet | 15 |
| Checking the Cabinet and Systems | 17 |
| Verifying the Express5800/320Fd Serial Number | 18 |
| Stabilizing the Systems | 19 |
| Disposing of Shipping Materials | 20 |
| What Happens Next? | 20 |
| System Documentation | 20 |

Introduction

Read Me First: Unpacking Express5800/320Fd Cabinets describes how to move cabinets that contain these systems to an installation site and how to unpack them.

Warnings, cautions, and notes in this document convey the following special information:



WARNING

A warning indicates a situation where failure to take or avoid a specified action could cause bodily harm or loss of life.



CAUTION

A caution indicates a situation where failure to take or avoid a specified action could damage a hardware device, program, system, or data.

NOTE

A note provides important information concerning the operation of your system.

Packaged Cabinet

Figure 1 shows a shipping container for a 38U cabinet that contains one or more systems and optional components. (“U,” for *unit*, equals 1.75 inches (in.), or 4.45 centimeters (cm).)

Figure 1. Cabinet Packaged for Shipping

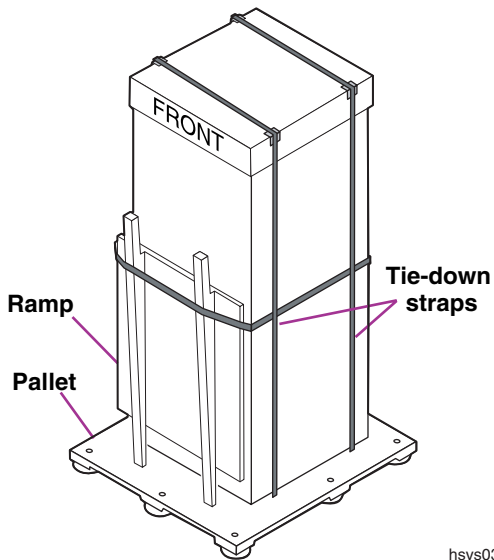

hsys032

The cardboard shipping container is secured to a shipping pallet by exterior shipping straps. (Inside the shipping container, interior shipping straps secure the cabinet to the pallet.) A ramp for rolling the cabinet off the pallet is attached to one side of the shipping container, at the rear of the cabinet. Labels on the cardboard cap indicate the front and rear of the cabinet.

Before Unpacking the Cabinet

1. Check the packing list to verify that you have received the correct shipment.
2. Verify that the Tip-N-Tell and Shockwatch handling indicators on the outside of the shipping container have not been activated.



CAUTION

If you received the wrong shipment or a handling indicator has been activated, **do not proceed with the unpacking**. Contact the vendor from which you purchased your system and the shipping carrier immediately.

3. Verify that the area through which you must move the cabinet has adequate clearance, as the following figures indicate:
 - [Figure 2](#) shows the dimensions of a packaged 38U cabinet.
 - [Figure 3](#) shows the dimensions of a packaged 24U cabinet.
 - [Figure 4](#) shows the clearances required at the installation site.

Include the height of the pallet jack when you calculate the overall cabinet height.

Figure 2. Dimensions of a Packaged 38U Cabinet

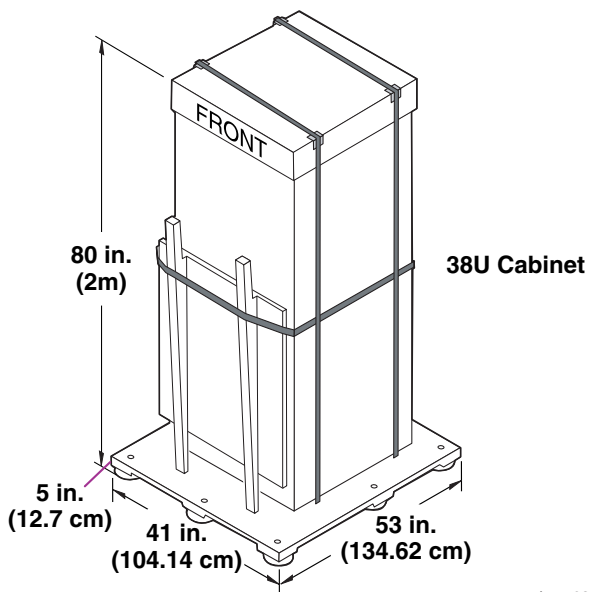

hsys033

Figure 3. Dimensions of a Packaged 24U Cabinet

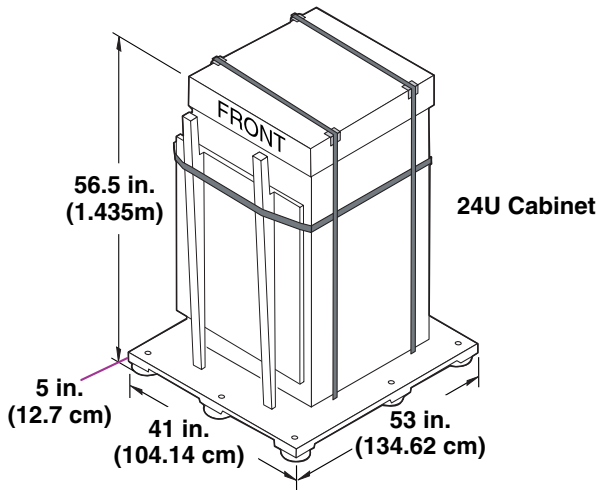

hsys034

Figure 4. Clearances Required at the Installation Site

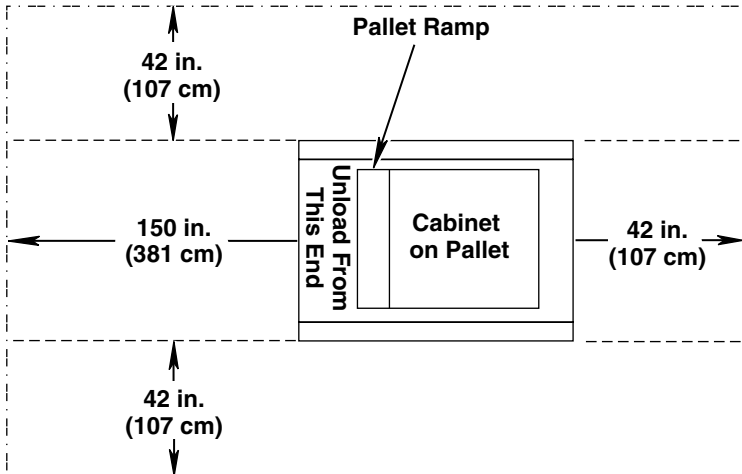

If the corridor and door dimensions are large enough to accommodate the unpacked cabinet still tied to its pallet, use a pallet jack to move it from the delivery site to the installation site, as described in [“Moving the Cabinet to the Installation Site”](#) on [page 6](#).

If the corridor and door dimensions are too small to accommodate the unpacked cabinet still tied to its pallet, unpack the cabinet and unload it from the pallet before you move it to the installation site. In this case, use the pallet jack to move the unpacked cabinet as close to the installation site as possible. Then, unpack the cabinet, remove it from its pallet, and roll it carefully on its casters to the installation site.

Moving the Cabinet to the Installation Site



WARNING

To avoid personal injury or damage to the systems or cabinet, two persons are required to move, unpack, and install a cabinet that contains Express5800/320Fd systems. Because of the size and weight of the systems in cabinets, consider using professional movers to deliver and move the packaged units to the installation site.



CAUTION

To prevent or minimize condensation on the systems' internal and external surfaces, avoid exposing the systems to extreme temperature or humidity changes when moving them to the installation site. If the systems have been exposed to extreme temperature or humidity conditions during transit, or if condensation is

present, see the section “[Stabilizing the Systems](#)” on [page 19](#) for stabilization guidelines.

When shipped, the system cabinet is tied to the pallet beneath it. The pallet has a clearance for a pallet jack to move the unit. When moving a system cabinet, follow these guidelines:

1. Verify that the unpacked cabinet is still secured to the pallet.
2. Use a pallet jack to move the cabinet on its pallet to the installation site.



CAUTION

Use a pallet jack to move the packaged cabinet, not a forklift. Using a forklift could damage the cabinet or a system. Use the pallet jack at the front or rear of the cabinet.

3. Position the cabinet pallet so that it has the clearances shown in [Figure 4](#).

Unpacking and Checking the Cabinet

Unless you have a service agreement that includes installation of the system, you need to unpack the cabinet.

To unpack the cabinet

- Make sure you have the correct tools.
- Remove the packing materials.
- Check the cabinet and system.
- Verify the system serial numbers.
- Remove the cabinet from its pallet.

Tools Needed to Unpack the Cabinet

Use the following tools to unpack the cabinet:

- Metal shears to cut pallet straps
- Pair of scissors or utility knife
- One 3/8-inch drive ratchet with a 9/16-inch socket

Removing the Packing Materials



WARNING

To avoid personal injury or damage to the systems or cabinet, two persons are required to perform the following procedures.

1. Orient the cabinet package so that the package and the ramp have, as a minimum, the clearance shown in [Figure 4](#). Also, verify that you have enough clearance above the cabinet to remove the top cardboard cap.
2. With one person holding the ramp in place, use the metal shears to cut the exterior shipping straps. To avoid injury while cutting each strap, hold the strap firmly with one hand as you stand away from it. See [Figure 5](#).



WARNING

The shipping straps can snap with considerable force when they are cut. To avoid eye or skin injuries, use caution when cutting the shipping straps.

Figure 5. Cutting the Exterior Shipping Straps

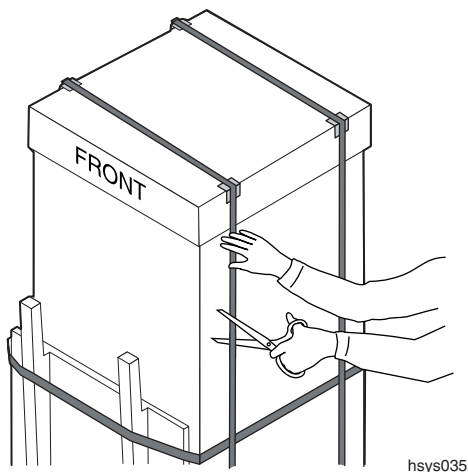

hsys035

3. Remove the ramp. The ramp is in two pieces that are held together by a bolt. Unbolt the two pieces. Behind the ramp is an accessory box, which contains various components and documentation. Remove the box and set it aside for later use.
4. Construct the ramp by inserting the bevel in the smaller ramp piece into the larger ramp piece. Set the ramp aside to use when you remove the cabinet from the pallet.
5. Remove the cardboard pieces of packing material surrounding the cabinet (see [Figure 6](#)). These pieces include two C-fold sleeves around the sides of the cabinet and a cap at the top.

Figure 6. Removing the Packing Material

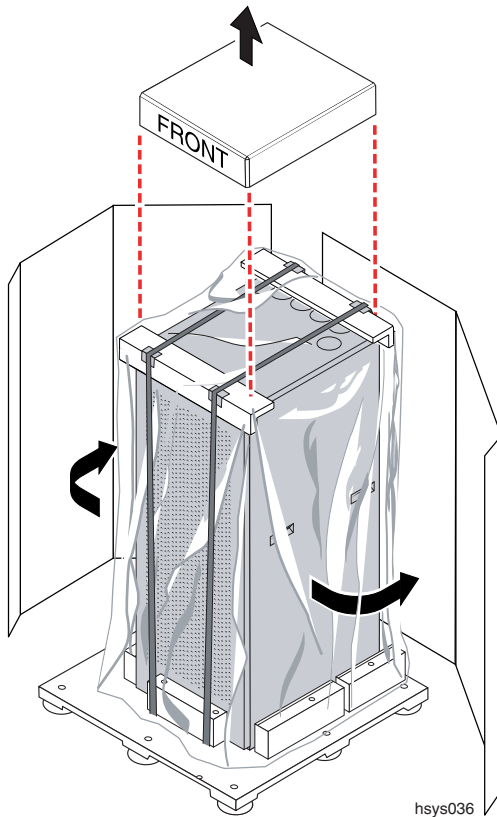

6. Remove the plastic wrap encasing the cabinet.



CAUTION

If condensation exists inside the plastic wrap, you must provide a stabilization period for the systems. [“Stabilizing the Systems” on page 19](#)

provides complete information about the stabilization process.

7. Use the strap buckles to loosen the interior shipping straps that secure the cabinet to the pallet. See [Figure 7](#).

Figure 7. Removing the Interior Shipping Straps

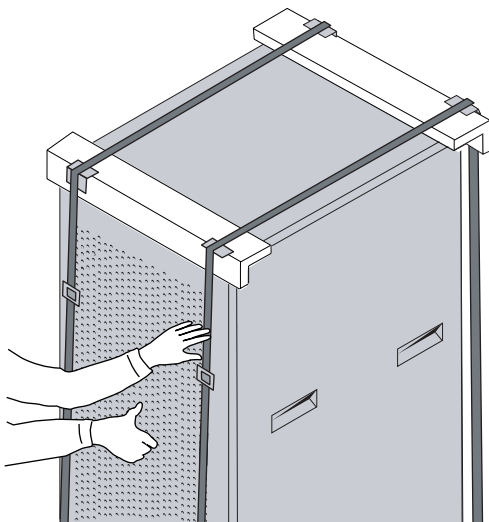

hsys037

8. Remove the two fiber protective sleeves at the top-front and top-rear of the cabinet.
9. Loosen, but do not remove, the bolts that secure the wooden-restraint blocks to the pallet at the bottom sides of the cabinet. See [Figure 8](#). (You do not need to loosen the bolts of the wooden-restraint blocks at the bottom rear of the cabinet.)

To loosen the bolts, use the 9/16-inch socket wrench. You may need to hold the nut underneath the pallet that secures the bolt.

Figure 8. Wooden-Restraint Blocks

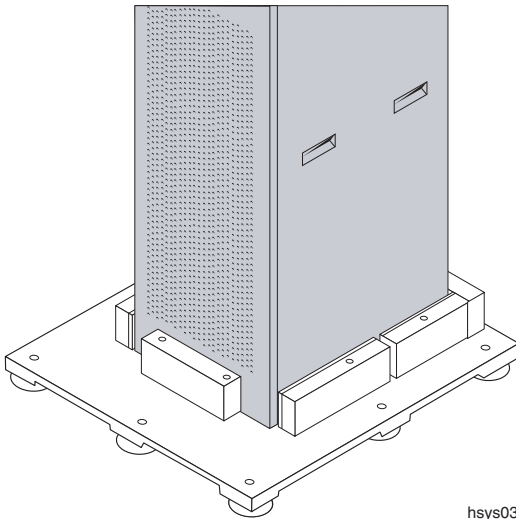

hsys038

10. Loosen and remove the bolts that secure the wooden-restraint block at the front door of the cabinet. Then, remove the block.
11. Locate the lever bar. Insert it in the center slot of one of the sides. See [Figure 9](#).

Figure 9. Inserting the Lever Bar

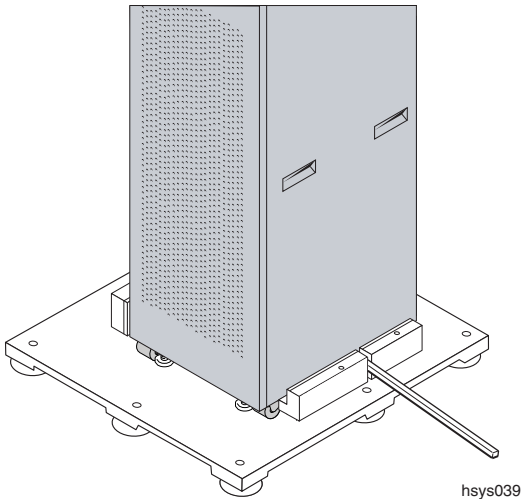

12. With the assistance of another person, tilt the cabinet from one side. As one person stands to brace the cabinet near the top, a second person kneels on the floor and uses both arms to push down on the lever bar, forcing the cabinet to tilt. See [Figure 10](#).

Figure 10. Tilting the Cabinet

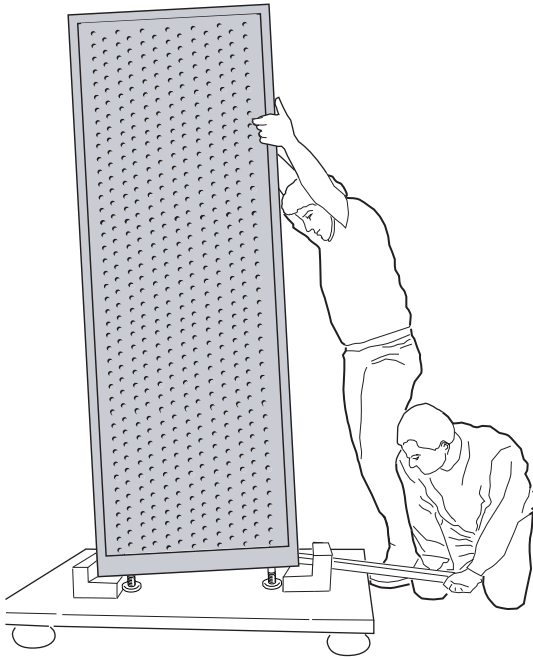

msys101

13. After the cabinet is tilted, the person who has been standing must kneel on the floor to slide the wooden restraint blocks away from the cabinet. See [Figure 11](#).

Figure 11. Sliding Back the Wooden Restraint Blocks

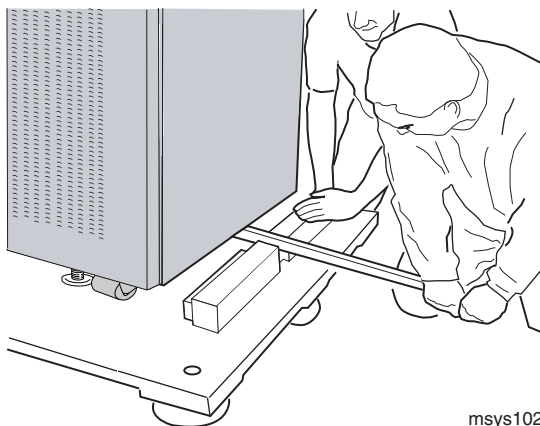

msys102

14. Move the lever bar to the opposite side of the cabinet. Repeat the process of tilting the cabinet and sliding back the two wooden restraint blocks on the opposite side of the cabinet.

Removing the Cabinet from the Pallet

1. Position the pallet ramp under the pallet, at the rear of the cabinet (see [Figure 12](#)). Verify that it is secure.

Figure 12. Position the Pallet Ramp

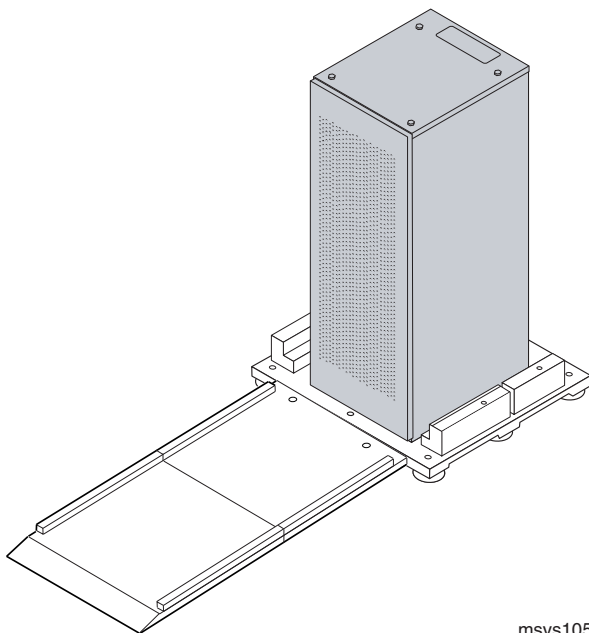

msys105

2. With the help of another person, slowly and carefully roll the cabinet down the ramp, with one person on each side of the cabinet, not in the front or back. See [Figure 13](#). Each person must hold the upper portion of the cabinet with both hands.



WARNING

The cabinet is top heavy. Use extreme caution when rolling it down the ramp.

Figure 13. Moving the Cabinet Down the Pallet Ramp

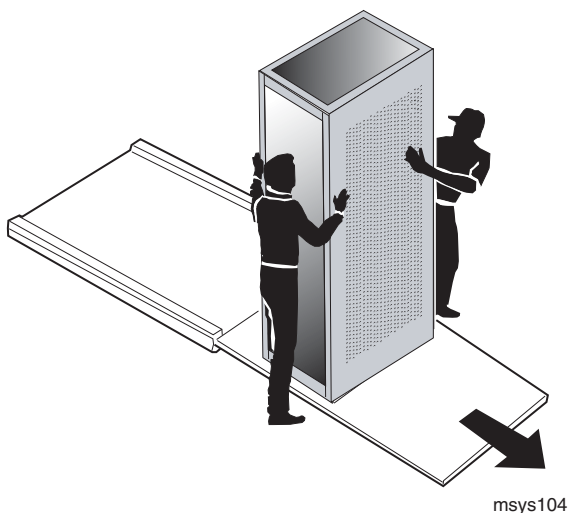

3. Check the cabinet and systems for damage, as the next section describes.

Checking the Cabinet and Systems

Check the cabinet, systems, and optional components for damage:

1. Open the rear door of the cabinet. From the bottom of the cabinet, remove and discard the desiccant bags.
2. Check the cabinet and systems for damage. Verify that the cabinets and panels have no dents, scratches, or scrapes.

If you notice damage, contact the vendor from which you purchased your systems. If you purchased your systems from NEC Corporation of America, contact the NEC Technical Support.

Verifying the Express5800/320Fd Serial Number

Find the equipment label to check the Express5800/320Fd serial number. To find the equipment label, open the rear door of the cabinet. The equipment label is attached to the rear of each system.

Check that the Express5800/320Fd serial number (not the Soletron[®] serial number) on the equipment label matches the Express5800/320Fd serial number on the packing list. If the numbers are not identical, contact NEC Technical Support before continuing to unpack the cabinet.

Stabilizing the Systems

If temperature and humidity changes have been extreme during transit, the cabinet and systems might develop condensation. Therefore, before you install and power on the systems, you must inspect them and the cabinet for condensation and, if necessary, stabilize the systems. To stabilize the systems, let the cabinet stand, unpacked and without its plastic wrap, in the open air of an office environment.

1. Inspect each cabinet and system for condensation. Use the guidelines in [Table 1](#) to determine if a system requires a stabilization period before you install it and power it on.

Table 1. Stabilization Guidelines

| Condition | Stabilization Period |
|---|-----------------------------|
| Desiccant is present. No condensation is on the plastic bag or system surfaces. | None |
| Desiccant is present. Condensation is on the plastic bag or on the cabinet or system surfaces. | 4 hours |
| Desiccant and plastic bag are missing. Condensation is on the cabinet or system surfaces. | 8 hours |

2. After the stabilization period, if you still notice signs of condensation inside or outside the cabinet, allow an additional stabilization period of two hours. Repeat the two-hour period, if necessary, until there are no signs of condensation. Then, continue to the next step.
3. Remove the desiccant bags and the cardboard tray in which they were shipped, if these items are still present.

4. Continue the installation, and continue to inspect for signs of condensation. If condensation appears, allow additional stabilization periods until there are no signs of condensation.



CAUTION

Before you power on the systems, verify that the installation site environment meets the requirements specified in the *Express5800/320Fd: Site Planning Guide*.

Disposing of Shipping Materials

The shipping materials contain no hazardous materials. Dispose of the shipping materials according to applicable procedures or local regulations. Stratus recommends, however, that you retain one or two undamaged containers and their shipping materials in case you need to repack the cabinet for later shipment.

What Happens Next?

To install a system, see the *Express5800/320Fd: Installation Guide*.

System Documentation

The **Express5800/320Fd Help and Manuals** are found on the ExpressBuilder CD shipped with your system. You can view the documents in the Help system or open them in PDF format for viewing or printing.

To gain access to the documents on the World Wide Web, point your browser to:

<http://support.necam.com/servers/>

Getting Help

If you have a technical question about Express5800/320Fd hardware or software, try these online resources first:

- **Online support from NEC Technical Support.** You can find the latest technical information about an Express5800/320Fd through online product support at the [NEC Technical Support Web site](#):

<http://support.necam.com/servers/ft>

- **Online product support for Microsoft® products.** Your primary source for support is the computer manufacturer who provided your software, or an authorized Microsoft Support Provider. You can also find the latest technical information about Microsoft Windows® and other Microsoft products through online product support at the [Microsoft Help and Support Web site](#):

<http://support.microsoft.com/>

If you are unable to resolve your questions with the help available at these online sites, and the Express5800/320Fd system is covered by a service agreement, please contact [NEC Technical Support](#) (866-269-1239).

